

PLANETARY GEARHEAD MPG42

● 外形尺寸 APPEARANCE SIZE

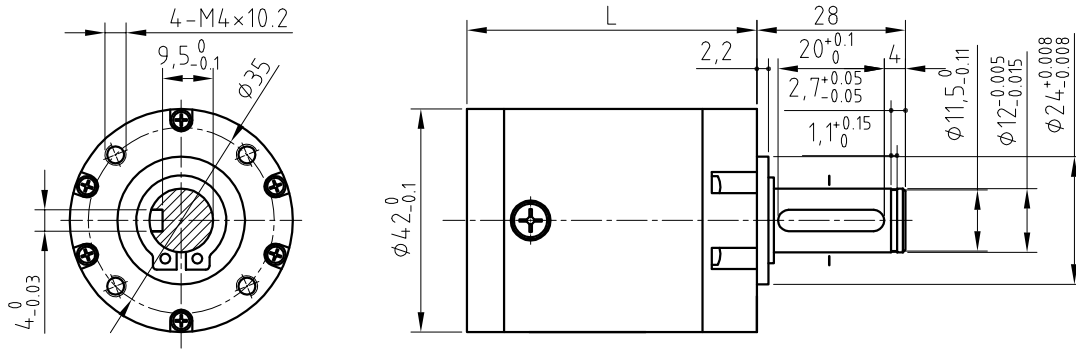

外壳材料 Housing material	金属 steel
齿轮材料 Gearwheel material	金属 steel ①
输出轴承型式 Bearing at output	滚动轴承 Ball bearings
径向负载 Radial load (10mm from flange)	≤25 Kgf
轴向负载 shaft axial load	≤15 Kgf
径向间隙 Radial play of shaft	≤0.04mm
轴向间隙 Thrust play of shaft	≤0.4mm
背隙 (无负载时) Backlash, at no-load	≤2°
连续运行时最高允许输入转速 Max permissible input speed at continuous working	≤40000rpm ②
工作温度范围 Operating temperature range	-60~100°C, -30~140°C

● 标准减速比型式 Gearboxes Specifications

减速比 (部分) Reduction ratio (part)	额定允许负载 rated tolerance torque	瞬间允许负载 Max momentary tolerance torque	效率 Efficiency	L (mm)
4.3, 5.1, 6.3, 7.6	65Kgf-cm	195Kgf-cm	93%	43.8
14.7, 16.3, 17.3, 18.6, 19.2, 21.9 23.9, 25.8, 27.2, 28.9, 32, 32.9 38.7, 39.7, 48, 58.1	86Kgf-cm	258Kgf-cm	86%	54.6
65.6, 74.6, 81.4, 90.5, 92.6, 98.5 109, 112.1, 117.2, 124.6, 132, 138 141.8, 146.7, 150.4, 162.4, 166.9 171.2, 182, 196.5, 201.5, 207.1 220.3, 243.9, 250.7, 295.2, 302.6 366.2, 443.2	108Kgf-cm	324Kgf-cm	80%	65.4
277.4, 315.8, 335.8, 342.8, 351 373.3, 382.2, 399.4, 413.2, 424.8 450, 459.3, 472.2, 483.4, 500.1 512.7, 537.4, 555.9, 569.1, 583.5 611.5, 620.6, 632.6, 648, 670 686.9, 706.2, 719.9, 744.7, 751.1 763.6, 785, 824.4, 831.4, 847.6 854.7, 869, 893.4, 924.2, 950.1 997.8, 1006, 1023, 1052, 1078 1081, 1119, 1147, 1238, 1269, 1272 1305, 1388, 1499, 1536, 1580, 1680 1860, 1907, 2251, 2307, 2793, 3380	130Kgf-cm	390Kgf-cm	75%	76.2